

CITY of PERTH

Design and Construction Note 420.02 Standard Kerb Types and Installation Details Precast Concrete Barrier Kerb

Reviewed: 15/12/2015

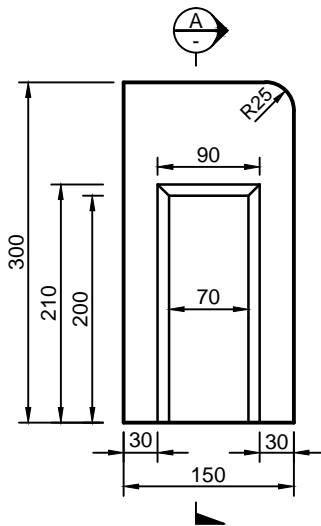

END ELEVATION

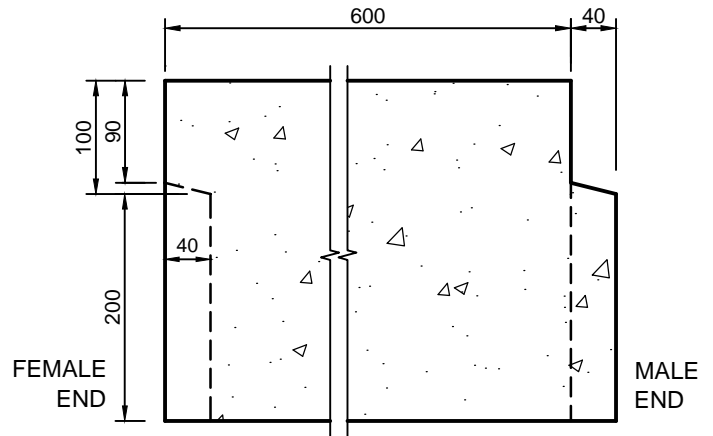

SECTION A

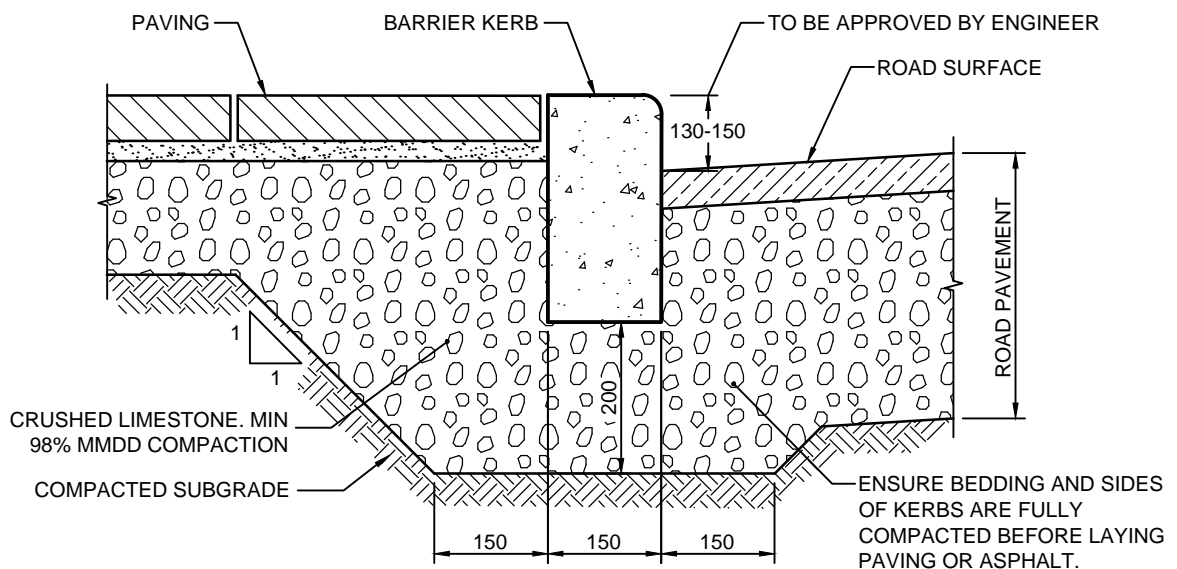

PRECAST BARRIER KERB LENGTH: 600mm

General Note:

1. For more information on concrete, mixing and tolerances of precast concrete kerbs refer *Design and Construction Note 420.01 - Precast Concrete Kerbs General Specification*.
2. Kerb heights at bus stops to be 150mm.